

THIS DRAWING IS UNPUBLISHED. RELEASED FOR PUBLICATION
 © COPYRIGHT BY TYCO ELECTRONICS CORPORATION. ALL RIGHTS RESERVED.

LOC	DIST	REVISIONS					
FT	0	P	LTR	DESCRIPTION	DATE	DWN	APVD
			A1	REVISED PER ECO-06-12428	5/26/06	SS	SRY

NOTES:

MATERIAL:
 HOUSING: THERMOPLASTIC, UL94V-0, BLACK.
 TERMINAL: BRIGHT TIN PLATED, COPPER ALLOY.
 SCREWS: NICKEL PLATED STEEL.

ELECTRICAL:
 RATED CURRENT: 10A.
 OPERATING VOLTAGE: 300V.
 WIRE RANGE: 16-30 AWG.

MECHANICAL:
 PITCH (TERMINAL SPACING): .250"
 OPERATING TEMP.: 120°C MAX.

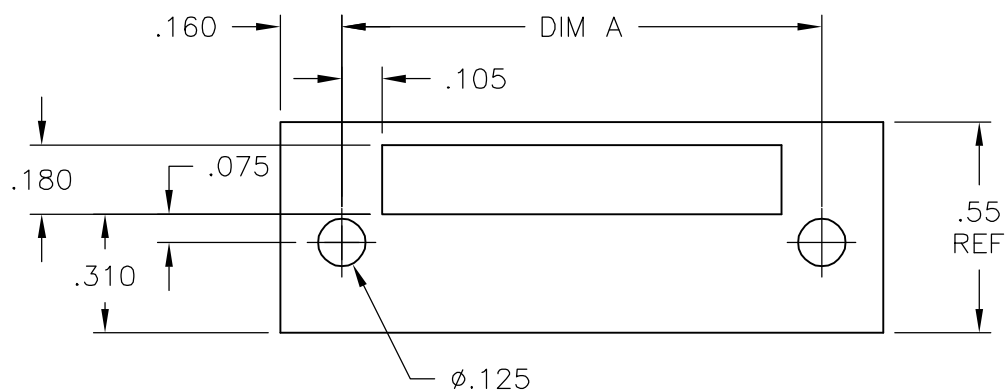
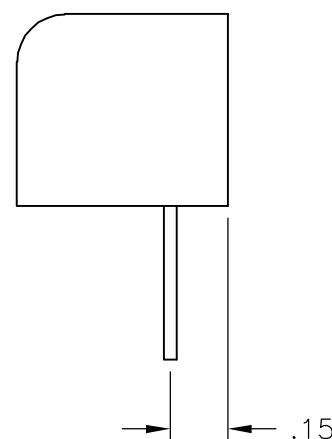
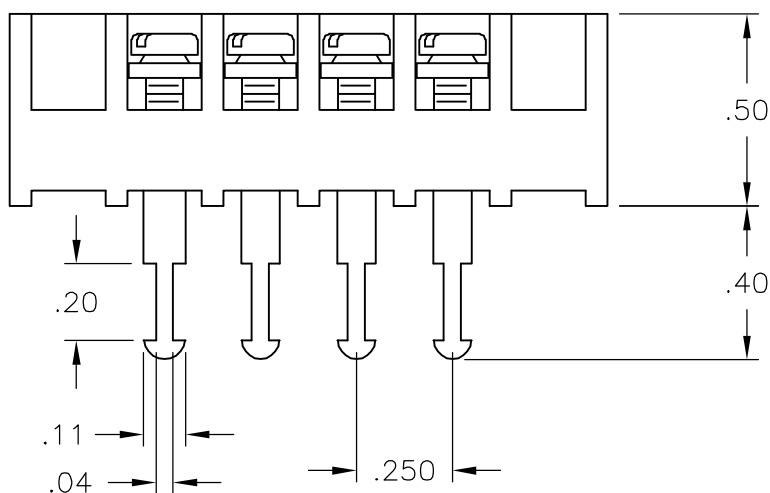
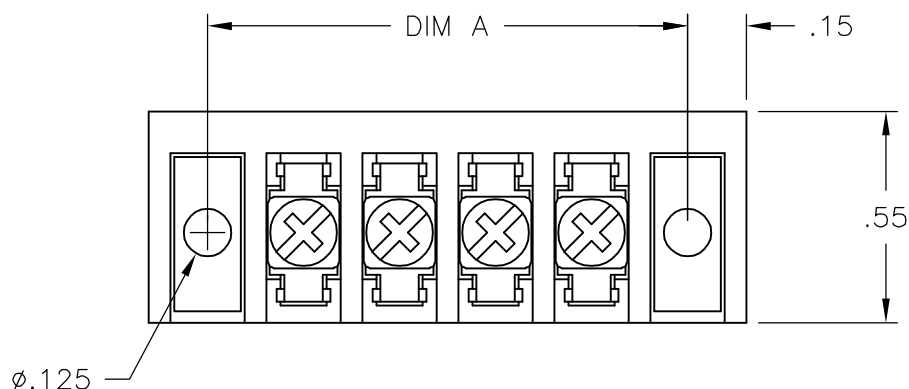

RECOMMENDED PANEL LAYOUT

7.25	28	3STV-28-006	2-1546687-8
7.00	27	3STV-27-006	2-1546687-7
6.75	26	3STV-26-006	2-1546687-6
6.50	25	3STV-25-006	2-1546687-5
6.25	24	3STV-24-006	2-1546687-4
6.00	23	3STV-23-006	2-1546687-3
5.75	22	3STV-22-006	2-1546687-2
5.50	21	3STV-21-006	2-1546687-1
5.25	20	3STV-20-006	6-1546119-3
5.00	19	3STV-19-006	1-1546687-9
4.75	18	3STV-18-006	1-1546687-8
4.50	17	3STV-17-006	1-1546687-7
4.25	16	3STV-16-006	1-1546687-6
4.00	15	3STV-15-006	1-1546687-5
3.75	14	3STV-14-006	1-1546687-4
3.50	13	3STV-13-006	1-1546687-3
3.25	12	3STV-12-006	6-1546119-2
3.00	11	3STV-11-006	1-1546687-1
2.75	10	3STV-10-006	6-1546119-1
2.50	9	3STV-09-006	6-1546119-0
2.25	8	3STV-08-006	5-1546119-9
2.00	7	3STV-07-006	5-1546119-8
1.75	6	3STV-06-006	5-1546119-7
1.50	5	3STV-05-006	5-1546119-6
1.25	4	3STV-04-006	5-1546119-4
1.00	3	3STV-03-006	5-1546119-3
.75	2	3STV-02-006	5-1546119-2

DIM "A"	NO. OF POS.	CATALOG NUMBER	TYCO PART NO.
---------	-------------	----------------	---------------

THIS DRAWING IS A CONTROLLED DOCUMENT.		DWN S SCHLEGEL 4/22/03	BUCHANAN Tyco Electronics Corporation Harrisburg, PA 17105	
DIMENSIONS: INCHES		CHK S YODER 4/22/03		
TOLERANCES UNLESS OTHERWISE SPECIFIED:		APVD S YODER 4/22/03	NAME 3STV-XX-006 ASSEMBLY	
0 PLC ± -		PRODUCT SPEC -	APPLICATION SPEC -	
1 PLC ± -		SIZE A3	CAGE CODE 00779	DRAWING NO C-5-1546119-2
2 PLC ± .02		RESTRICTED TO -		
3 PLC ± .010		SCALE NTS		
4 PLC ± -		SHEET 1 OF 1		
ANGLES ± -		REV A1		
FINISH -		CUSTOMER DRAWING		